

OPS-A2



GENERAL SPECIFICATIONS

Device Type	Open Pluggable Specification (OPS)
Operating System	Android 14 (Android 16 OTA update, summer 2026)
CPU	ARM Cortex A72 x4 + A53 x4
GPU	ARM Mali-G52 MC3
RAM	8 GB, DDR5
Internal Storage	64 GB eMMC
Touchscreen Compatibility	Yes
TPM	2.0
Architecture	ARM v8-A, 64 bit
Display Resolution	4K UHD 3840 x 2160 @ 60 Hz

CONNECTIVITY

USB-A 3.0	x2
USB-B (Touch)	x1
USB-C (Data only)	x1
HDMI In (4K @ 60 Hz)	x1
HDMI Out (4K @ 60 Hz)	x1
Microphone In (3.5 mm)	x1
Headphone (3.5 mm)	x1
Network (RJ45)	Realtek 8111H, 10/100/1000 Mbps
Wi-Fi	Wi-Fi 6 (Dual band 2.4 GHz and 5 GHz)
Bluetooth	5.2
Expandable Storage (MicroSD)	x1

POWER

Power Requirements	12-19 V DC
Power Consumption Maximum	36 W
Power Consumption Standby	0.5 W

ENVIRONMENTAL

Operating Temperature	0 °C to 40 °C (32 °F to 104 °F)
Storage Temperature	-20 °C to 60 °C (-4 °F to 140 °F)
Operating Humidity	10% to 90% non-condensing
Storage Humidity	10% to 90% non-condensing

PHYSICAL SPECIFICATIONS

Product Dimensions	200 x 120 x 30 mm (7.9 x 4.7 x 1.2 in)
Packed Dimensions	265 x 212 x 50 mm (10.4 x 8.4 x 2 in)
Net Weight	0.7 kg (1.5 lb)
Packed Weight	0.84 kg (1.85 lb)

USABILITY

Promethean Essential Apps	Including Whiteboard, Screen Share, Screen Capture, Annotate, Spinner, and Timer
Google Apps	Including Play Store, Chrome, Drive, Meet, and YouTube

PACKED CONTENTS

What's in the box	OPS-A x1, Antenna x3, Installation Guide x1
-------------------	---

COMPLIANCE & CERTIFICATION

EDLA Certification	Yes
Regulatory Certifications	CB, CE, FCC, UL, RoHS

WARRANTY

Standard Warranty	Three-Year Warranty. For more information, visit PrometheanWorld.com/Warranty .
-------------------	--

INSTALLATION

The installation of this product should be completed by a qualified installer. Use of components not supplied by Promethean or not meeting minimum specifications may impact performance, safety and warranty. For more information, visit [Support.PrometheanWorld.com](https://www.prometheanworld.com).

SUPPORT

For all Promethean products, visit [Support.PrometheanWorld.com](https://www.prometheanworld.com).

OPS-A2

TECHNICAL DRAWINGS

Top

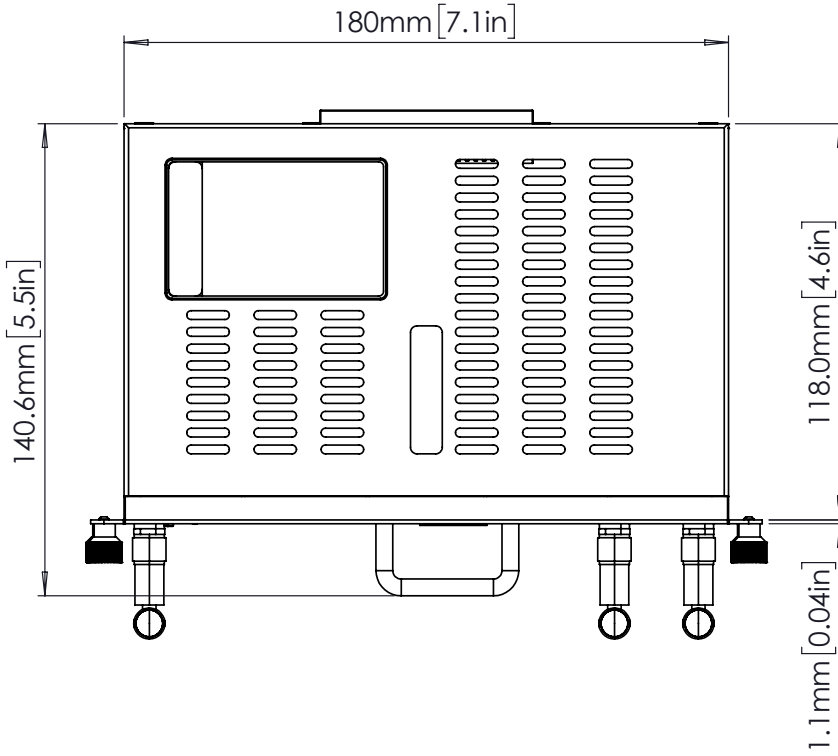

Front

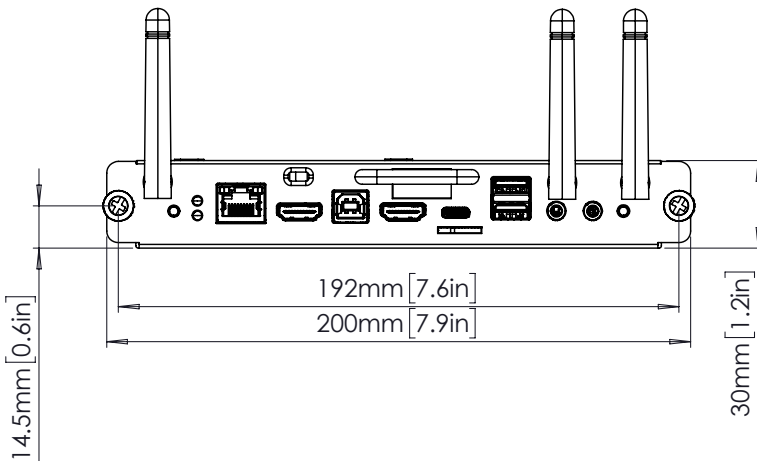

Side

